

SIC2004 ANALYTICAL CHEMISTRY I / SIC2022 BASIC ANALYTICAL CHEMISTRY / SID2003 BASIC ANALYTICAL CHEMISTRY

Laboratory Manual



UV-VIS



FAAS

GC - FID



**ISE
METER**

CONTENTS

I) INTRODUCTION

Preparation for Laboratory Sessions

Reports

Safety Procedures in the Laboratory

General Instructions

General References

Marking Scheme

II) EXPERIMENTAL WORKS

Expt. 1 : Statistical Treatment of Raw Data

Expt. 2 : Complexometric Titration of Metal Ion

Expt. 3 : Spectrophotometric Determination of Manganese in Steel

Expt. 4 : Elemental Analysis by Flame Atomic Spectroscopy

Expt. 5 : Separation of Anions by Ion Exchange Chromatography

Expt. 6 : Introduction to Gas Chromatography

Expt. 7 : Direct Potentiometry Using Ion Selective Electrode

INTRODUCTION

In chemical analysis, a wide range of experimental procedures is used to do two separate jobs. Procedures which establish the identity of the elements, ions, molecules or functional groups which are present in a sample, are those of *qualitative analysis*. Other procedures which are used to find out as precisely as possible how much of each of the individual components of a sample is present, are those of *quantitative analysis*.

Many of the methods of quantitative analysis, whether for inorganic or organic compounds, are based on a reaction involving formation of compounds of definite stoichiometry, either as solids or in solution, and then relating the amount of these compounds formed to the amount of a particular component in the sample.

One of the simplest forms of quantitative analysis is *gravimetric analysis*. A specific reagent is used to precipitate the component from solution as an insoluble compound of definite stoichiometry. The precipitate is separated, washed, dried and weighed. The amount of the component in the precipitate can be calculated from the weight of the precipitate and then the required percentage of the component in the original sample. Many examples of this type of analysis are included in the first year Chemistry practical courses as well as SIC 2004/SID2003/SIC2022.

The second major field of quantitative analysis is based on *volumetric techniques*. Concentrations of entities for analysis are calculated by relating the volumes of solutions which react to completion in a stoichiometric reaction. In this course, oxidation-reduction or complex-formation reactions coupled with indicators have been used. The end points are determined either visually or instrumentally.

Trends in modern analysis are away from gravimetric and volumetric analysis towards *instrumental analysis* (although these classical techniques are still very important). Most instrumental procedures are either *electrometric, chromatographic or spectroscopic*. In the latter, the amount of radiation absorbed or emitted by a sample is measured. Using a calibration based upon similar measurements for solutions of known composition, the concentration in the unknown sample may be derived. Many types of radiation are used in instrumental techniques of analysis – visible, ultra-violet, infra-red, etc.

Reliable sampling and dissolution procedures are vital for successful chemical analysis. It is obvious that a non-homogeneous solid specimen cannot be accurately analyzed unless the whole specimen is dissolved or unless it is rendered uniform, e.g. by very fine grinding, so that a truly representative sample of it can be obtained. Similarly, any solution prepared from the solid sample for gravimetric, volumetric or instrumental analysis must contain all of the components to be determined and that component must be totally available for analysis.

It is not intended that this course can or should produce skilled analysis. To do so would require several years of undergraduate and postgraduate experience. It is hoped that students progressing from this course will have some general understanding of relatively simple analytical procedures, of their reliability (from a consideration of sources of errors, sensitivity of a particular technique, etc.) and of their limitations (from a consideration of potential or real interference by other possible components of the sample being analyzed).

PREPARATION FOR LABORATORY SESSIONS

It is essential to make adequate preparation for each day's practical work. Read relevant sections for the experiment time-tabled for you and plan each step of your work **before you come into the laboratory**. You should clearly understand the aim of the experiment before commencing the practical work.

All notes you make in the laboratory of observations and measurements **must** be in an exercise book, and not on scraps of paper. The notes should be kept tidy as it will be assessed together with the experimental report.

REPORTS

You must submit to your laboratory supervisor a report on each experiment within 7 days of the completion of the experiment. Failure to do so will result either in reduction in the grade or the report will be not graded at all. Each report should contain :

- a) Title page (including name, name partner, experiment number, title experiment, dates experiment commenced and completed).
- b) Objectives and brief introduction or basic theory.
- c) Experimental procedure, including any suggested modifications to the issued instructions.
- d) Experimental results should be given and set out as neatly and clearly as possible, preferable in well tabulated form.
- e) Calculations of quantities derived from your experimental data.
- f) Your final results with an assessment of their accuracy.
- g) Brief discussion with emphasis on the procedure, technique, short-coming, etc.
- h) Answers to questions
- i) Conclusion
- j) References

SAFETY PROCEDURES IN THE LABORATORY

Some of the important aspects of safety related to this course is given below :

- a) Safety glasses **MUST** be worn at **all** times in the laboratory.
- b) Shoes **MUST** be worn at **all** times in the laboratory.
- c) **Eating, drinking or smoking** in the laboratory is forbidden.
- d) The faulty handling of glass apparatus can result in severe cuts. If rubber or plastic tubing is being pushed onto glass tubing, the glass must have its end fire-polished. Always grasp the glass tubing close to the end to which the flexible tubing is being attached.
- e) The possibility of **accidental electric shock** should always be kept in mind when using mains operated equipment. Make sure both the equipment and its cord are kept away from water and report any defective cords, switches or plugs to the supervisor. Do not open the outer casing of any mains operated apparatus without permission.
- f) Organic solvents
 - (i) Most organic solvents are highly flammable and must not be used near flames

- (ii) Common organic solvents such as benzene, carbon tetrachloride, chloroform and toluene can be very harmful if inhaled in high concentrations. Whenever possible these solvents should be used in the fume cupboard.
 - (iii) **Do not dispose** of organic solvents in the laboratory sinks; they should be disposed of in the appropriate residue bottles located in the fume cupboards.
- g) Except for the most trivial episode, **all accidents must be reported to the laboratory authority** (*lab. Supervisor, lab. Assistant or tutor*).

GENERAL INSTRUCTIONS

- 1) Students will work in pairs, and are required to submit individual reports for the experiments performed.
- 2) The students should take utmost care to keep the laboratory tidy and clean.
- 3) All glassware, chemicals and other apparatus should be returned to the proper places where you have taken them from. Failure to return any apparatus or glassware borrowed will mean that the department will automatically bill the items under your account.
- 4) If a piece of equipment is missing, damaged, or not functioning correctly, report this at once.

GENERAL REFERENCES

- 1) A.I. Vogel, "A text-book of macro and semi micro qualitative Inorganic Analysis", Longmans
- 2) A.I. Vogel, "A Text-book of Quantitative Inorganic Analysis", Longmans
- 3) D.A. Skoog and D.M West, "Fundamentals of Analytical Chemistry"

Suggested Detailed Rubrics for Level II and III Laboratory Classes

Section A: Attendance and Responsibility (Total 20%)

1. Attendance (5%)

Score	Criteria
0	Student did not attend without any valid reasons.
5	Student is present.

2. Pre-entering lab (5%)

Score	Criteria
0	No preparation of experimental procedure.
3	Summary of procedures too brief, lack of details and confusing.
5	Presents easy to follow steps in lab experimental, logical and adequately detailed.

3. Proper attire (5%)

Score	Criteria
0	No proper attire – covered shoes, safety goggles and lab coat.
3	Covered shoes and lab coat available but no safety goggles.
5	Safety attire checked.

4. Promptness (5%)

Score	Criteria
0	Student is late for more than 15 minutes without any valid reasons.
3	Student is late for not more than 15 minutes without any valid reasons.
5	Student is always prompt.

Notes:

1. The student **MUST** attend the laboratory session to be eligible for obtaining marks. **NO** marks will be given at all if the student did not attend any laboratory sessions without valid reasons.

2. If the student did not attend any of the laboratory session, there **MUST** be an official explanation (i.e., if Covid-19: MySejahtera Screenshot; Sick: MC from doctor; representing UM in activities: Official Letter from the Department/Faculty/University, etc.; Family reasons: Death of family member, etc.).

Section B: Lab Performance – Skills and Technique (Total 20%)

Score	Criteria
0-5	No skill is demonstrated.
6-10	Wrong glassware used, wrong technique, spillage and wasting of chemicals.
11-15	Right glassware used, incorrect or lack of lab technique.
16-20	Presents correct lab skills, clean and tidy.

Section C: Lab Jotter (Total 10%)

Score	Criteria
0	No jotter or student did not show raw data to the lecturer-in-charge; student exhibit evidence of data forging and/or plagiarism.
1-3	Raw data are out-of-place; major data or observations missing; no proper labeling.
4-6	Some key data or observations are missing. Presentation need major improvement.
7-8	Almost all raw data and key observations written. Presentation can still be improved.
9-10	Raw data and observations tabulated/written in a clear and tidy manner, with correct units and no evidence of data forging and/or plagiarism.

Section D: Lab Report (Total 40%)

(I) Short Report

Section	Score	Criteria
Title & Objectives (5 marks)	0	No title and objectives
	1	Too brief (e.g. "Lab Report", "Mercury in Fish", "Synthesis of Cinnamic Acid" or "Boiling Point of Water").
	2-3	Too long or does not identify the complete subject of study (e.g. "Determination of iron", "Determination of lead", etc.).
	4-5	Identify the complete subject of study and encapsulates the purpose of the report/study (e.g. "Kinetics of the hydrolysis of <i>t</i> -butyl chloride at 30 °C", "Synthesis of triphenylcarbinol via Grignard reaction" or "Determination of iron in red meat via spectrophotometry").

Results (Data, figures, graphs, tables, observations, % yield, etc.) (35 marks)	0	Section missing completely.
	1-10	No flow of results. Figures, graphs, tables contain errors or are poorly constructed, have missing titles, captions or numbers, units missing or incorrect, numerical data did not have correct significant figures, etc.
	11-20	Most figures, graphs, tables OK, some still missing some important or required features.
	21-30	All figures, graphs, tables are correctly drawn, but some have minor problems (e.g. incorrect significant figures, incomplete observation) or could still be improved.
	31-35	All figures, graphs, tables are correctly drawn, are numbered and contain titles/captions. Observations clearly stated. Numerical data contains correct significant figures and units.
Discussion (35 marks)	0	Section missing completely.
	1-10	Lack of attempt to relate experimental findings and data with contemporary theories. Very incomplete or incorrect interpretation of trends and comparison of data indicating a lack of understanding of results.
	11-20	Some attempt to relate experimental findings and data but using inaccurate theories. Some of the results have been correctly interpreted and discussed; partial but incomplete understanding of results is still evident.
	21-30	Almost all of the results have been correctly interpreted and discussed, only minor improvements are needed.
	31-35	All of the important trends and data comparisons have been interpreted correctly and discussed; good understanding of results is conveyed.
Safety Precautions (5 marks)	0	Section missing completely.
	1	Sentences are incomplete, focusing on minor points or lack important steps.
	2-3	State only 1-2 major and most important safety precautions.
	4-5	State at least 3 major and most important safety precautions.
Conclusions	0	Section missing completely.

(10 marks)	1-3	Conclusion missing the important points or is not supported by the experimental results.
	4-6	Conclusions regarding major points are drawn, but many are misstated, indicating a lack of understanding.
	7-8	All important conclusions have been drawn, could be better stated.
	9-10	All important conclusions have been clearly made, student shows good understanding.
References (5 marks)	0	Section missing completely.
	1-3	Incomplete references to the books or any other sources used in the report.
	4-5	Correct in-text citations and the references in the reference list conform to all respects of the formatting convention (e.g. APA format). Complete references to the books or any other sources used in the report. References in text are matched with references in the reference list (e.g. no missing references).
Appearance and Formatting (5 marks)	1	Sections out of order, too much handwritten copy, sloppy formatting.
	2	Sections in order, contains the minimum allowable amount of handwritten copy, formatting is rough but readable.
	3	All sections in order, formatting generally good but could still be improved.
	4-5	All sections in order, well-formatted, very readable.

Total section D marks = $(x/100) \times 40\%$

(II) Full Report

Section	Score	Criteria
Title (5 marks)	0	No title.
	1	Too brief (e.g. "Lab Report", "Mercury in Fish", "Synthesis of Cinnamic Acid" or "Boiling Point of Water").

	2-3	Too long or does not identify the complete subject of study (e.g. "Determination of iron", "Determination of lead", etc.).
	4-5	Identify the complete subject of study and encapsulates the purpose of the report/study (e.g. "Kinetics of the hydrolysis of <i>t</i> -butyl chloride at 30 °C", "Synthesis of triphenylcarbinol via Grignard reaction" or "Determination of iron in red meat via spectrophotometry").
Introduction (Including objectives) (10 marks)	0	Section missing completely.
	1-3	Very little background information provided, or information is incorrect.
	4-6	Some introductory information, but still missing some major points.
	7-8	Introduction is nearly complete, missing some minor points.
	9-10	Introduction complete and well-written; provides all necessary background principles for the experiment with evidence of extra reading.
Experimental Procedure (10 marks)	0	Section missing completely.
	1-3	No sub-sections, missing several important experimental details or not written in paragraph format. Parts have been included under the wrong sub-section.
	4-6	Written in paragraph format, still missing some important experimental details.
	7-8	Written in paragraph format, important experimental details are covered, some minor details missing.
	9-10	Well-written in paragraph format, all experimental details are covered.
Results (Data, figures, graphs, tables, observations) (25 marks)	0	Section missing completely.
	1-7	No flow of results. Figures, graphs, tables contain errors or are poorly constructed, have missing titles, captions or numbers, units missing or incorrect, numerical data did not have correct significant figures, etc.
	8-15	Most figures, graphs, tables OK, some still missing some important or required features.

	16-20	All figures, graphs, tables are correctly drawn, but some have minor problems (e.g. incorrect significant figures, incomplete observation) or could still be improved.
	21-25	All figures, graphs, tables are correctly drawn, are numbered and contain titles/captions. Observations clearly stated. Numerical data contains correct significant figures and units.
Discussion (25 marks)	0	Section missing completely.
	1-7	Lack of attempt to relate experimental findings and data with contemporary theories. Very incomplete or incorrect interpretation of trends and comparison of data indicating a lack of understanding of results.
	8-15	Some attempt to relate experimental findings and data but using inaccurate theories. Some of the results have been correctly interpreted and discussed; partial but incomplete understanding of results is still evident.
	16-20	Almost all of the results have been correctly interpreted and discussed, only minor improvements are needed.
	21-25	All of the important trends and data comparisons have been interpreted correctly and discussed; good understanding of results is conveyed.
Safety Precautions (5 marks)	0	Section missing completely.
	1	Sentences are incomplete, focusing on minor points or lack important steps.
	2-3	State only 1-2 major and most important safety precautions.
	4-5	State at least 3 major and most important safety precautions.
Conclusions (10 marks)	0	Section missing completely.
	1-3	Conclusion missing the important points or is not supported by the experimental results.
	4-6	Conclusions regarding major points are drawn, but many are misstated, indicating a lack of understanding.
	7-8	All important conclusions have been drawn, could be better stated.

	9-10	All important conclusions have been clearly made, student shows good understanding.
References (5 marks)	0	Section missing completely.
	1-3	Incomplete references to the books or any other sources used in the report.
	4-5	Correct in-text citations and the references in the reference list conform to all respects of the formatting convention (e.g. APA format). Complete references to the books or any other sources used in the report. References in text are matched with references in the reference list (e.g. no missing references).
Appearance and Formatting (5 marks)	1	Sections out of order, too much handwritten copy, sloppy formatting.
	2	Sections in order, contains the minimum allowable amount of handwritten copy, formatting is rough but readable.
	3	All sections in order, formatting generally good but could still be improved.
	4-5	All sections in order, well-formatted, very readable.

Total section D marks = $(x/100) \times 40\%$

Section E: Assessment of Understanding/Revision on Conducted Experiments (10%)

Score	Criteria
x	Test/Quiz/Lab Presentation, etc.

* For Section E: Assessment - it is up to the lecturer in-charge to decide whether he/she wants to carry out the method of assessment (simple test, presentation, etc). If he/she chooses not to, the 10% marks will be allocated back to Section D: Lab report (i.e. total marks/100 \times 50%)

** Late Report Submission: -1 mark / day

STATISTICAL TREATMENT OF RAW DATA**1. INTRODUCTION**

There are three steps in establishing the results of an analysis. In **Step 1** we record, in an appropriate manner, the data as they are obtained. Recording experimental data is usually done by writing the observations, as they are made, in ink in a hardbound laboratory notebook. In **Step 2** we decide the best value of the results to report. Usually multiple measurements (replicates) are obtained for a given sample. *For example, a soil sample from a landfill may yield the following results for chromium: 20.8, 20.2, and 15.7 ppm.* The analyst must decide on a value to report that best characterizes the sample under study. The value reported is often the mean value. In **Step 3** we indicate the precision (scatter) of the results. This indicates the homogeneity of the samples, the appropriateness of the method for the sample, and also the care and skill of the experimenter.

1.1 Best Value

The value reported is frequently the arithmetic mean although the geometric mean is useful if there is an outlier. Another important reported value is the median.

Arithmetic Mean or Average — This best value is the sum of the individual measurements divided by the number of measurements, mathematically given by **Eq 1-1**:

$$\bar{X} = \frac{(X_1 + X_2 + \dots + X_N)}{N} = \frac{\sum X_i}{N} \quad \text{(Eq 1-1)}$$

where \bar{X} is the mean, the X_i are the individual results, and N is the total number of results.

Median — This measure is simply the "middle" value. When all results are listed in order of increasing value, it is the middle result if the number of values is odd. If the number of results is even, it is the average of the two middle values. The median is not used as often as the arithmetic mean.

Accuracy — how close a result or best value is to the true value. The true value is the exact answer or result of an analysis. This value is often unknown. The uses of carefully prepared and analysed standards will produce a value that is often used as a true value (synonyms: accepted, actual, authentic, right, and correct).

Measurements of Accuracy

Absolute Error — The absolute value of the difference between an individual result and the true value, $|X_i - \mu|$, where, μ is the true value.

Relative Error — The absolute error divided by the true value. Often expressed as percent or parts per thousand (ppt) when multiplied by 100 or 1000, respectively. The

relative error is equal to $\frac{|X - \mu|}{\mu} \times 100\%$ or $\frac{|X - \mu|}{\mu} \times 1000\text{ppt}$.

Precision — the closeness of the results in a set of replicate analyses to each other.

Measurements of Precision

Range — The "spread" of the results. The largest value minus the smallest value is the range (w) of a set of measurements.

Relative Range — The range divided by the mean value for the data set. This value is often expressed as a percentage.

Deviation — The absolute value of the numerical difference between a given result and the mean (analogous to the absolute error), $d_i = |X_i - \bar{X}|$.

Average Deviation — The average of the individual deviations, $\sum d_i/N$, where N is the total number of replicates.

1.2 Uncertainty

Measurements made using an instrument are subject to some uncertainty due to estimating the position between graduations. For an **analytical balance** the uncertainty in a measured mass is at least 0.0001 g. Thus, a 5.5512 g mass can be between 5.5511 and 5.5513 g. A reasonable uncertainty is $\pm 1/2$ the distance between the smallest graduations. A **burette** usually has graduation marks every 0.1 mL, and the liquid level between marks can be estimated to no better than the nearest 0.01 mL for an experienced analyst. Uncertainty is the precision of a single measurement. Even a digital readout has an uncertainty. When you look at the illuminated numbers of a digital readout, you usually see small fluctuations in the last digit. The uncertainty in a measurement is taken to be ± 1 in the final digit. Uncertainty expressed in the units that are measured is called the absolute uncertainty. The relative uncertainty is the absolute uncertainty divided by the number measured multiplied by 100 or 1000 to give the relative uncertainty in percentage or ppt.

Error Analysis — Types of Errors

The interpretation of results that are not exact requires an analysis of errors. A report of experimental results must include a discussion of errors observed or inferred from the data. Experimental measurements are affected by two principal types of error. **Random errors**, also called indeterminate errors, result in deviations that may be either positive or negative. Random errors cause to be spread somewhat symmetrically about the mean value if there are no other errors present. It is difficult to ascribe exact causes to random errors; however, much research has been done to minimize random errors in analytical instruments.

If errors are truly random, it is possible to approximate a true value by using the average measurement for a sufficiently large number of samples (or analyses). To determine whether "enough" analyses have been performed, a few more are carried out and the average calculated after each new measurement. If the average does not change (significantly), the average is acceptable.

The second type of error commonly found is **systematic**, or **determinant error**. This type of error causes the mean of a data set to differ from the true value of the sample. Generally, a systematic error causes the results of replicate analyses to be consistently high or consistently low.

A third type of error frequently encountered, especially in dealing with environmental samples, is **gross error**. A gross error results in an outlier that is very different in value than the remainder of the results. The type of error may be due to an inhomogeneity in the sample (poor sampling), the presence of a contaminant or making a mistake in reading a buret or balance.

Random Errors and the Distribution of Experimental Results

The cause of a gross error can be determined and eliminated, although this may not be easy in practice. Systematic errors also can be located and eliminated. If a high buret reading is constantly made or if an indicator change is not intense enough to be seen, results will be consistently high for the analysis. The errors can be eliminated, however. Another systematic error is due to a slow titration reaction and can be eliminated by heating the titration mixture. On the other hand, random errors cannot be eliminated and result in a spread, or distribution of results symmetrically distributed about the mean value.

To illustrate the effect of random errors on results, consider the following examples. First suppose that an analysis is carried out carefully so that only random errors occur. To start with the simplest possible situation, imagine that there are just two indeterminate errors in the experiment. An example of this type is reading a buret two times to obtain the volume of a titrant. If the magnitude of the random error is constant, and equal to 0.05 mL, there are three possible results: (1) both errors are positive, giving a total random error of +0.10 mL; (2) both errors are negative, giving a total random error of -0.10 mL; or (3) one error is positive and one error is negative, giving a random error of 0.00 mL.

There is just one way the error can be +0.10 mL and that is for both errors to be positive. The same is true for the error of -0.10 mL. The error of 0.00 mL is two times as probable since there are two ways it can occur: (1) the first measurement being high by 0.05 mL, the second measurement being low by 0.05 mL and (2) the first measurement being low by 0.05 mL and the second measurement being high by 0.05 mL. Thus, if only random errors are present, errors in measurements tend to even out.

Let's now consider a more complex situation, one where there are three equal random errors. We shall consider this to result from reading a burette two times and estimating the equivalence point in a titration. The possible errors, and the ways in which these can be achieved, are shown below. An arrow pointing upward represents an error of +0.05 mL and an arrow pointing downward represents an error of -0.05 mL.

$$\begin{array}{cccc}
 \begin{array}{c} \downarrow\downarrow\downarrow \\ -0.15 \text{ mL} \end{array} & \begin{array}{c} \downarrow\downarrow\uparrow \\ \downarrow\uparrow\downarrow \\ \uparrow\downarrow\downarrow \\ -0.05 \text{ mL} \end{array} & \begin{array}{c} \uparrow\uparrow\downarrow \\ \uparrow\downarrow\uparrow \\ \downarrow\uparrow\uparrow \\ +0.05 \text{ mL} \end{array} & \begin{array}{c} \uparrow\uparrow\uparrow \\ +0.15 \text{ mL} \end{array}
 \end{array}$$

Another way to express these results is to plot the number of ways each error can occur versus the value of the error. This is shown in **Figure 1.1**, where the curve is the expected distribution for a larger number of random errors.

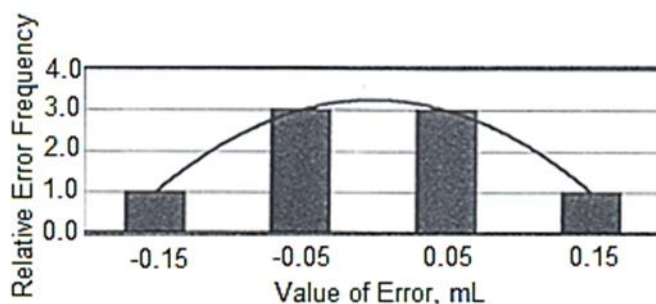

Figure 1.1 Frequency of Errors Versus Value of the Error for Three Equal Errors.

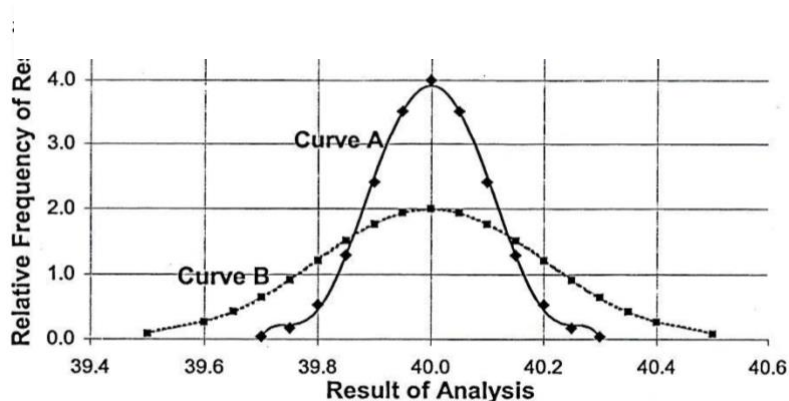

Figure 1.2 Gaussian curve.

To understand the importance of this ideal curve, which is called Gaussian, or a normal distribution (the curve is called a bell curve and is how grades are ideally supposed to be distributed), we first examine its mathematical form. **Figure 1-2** shows the Gaussian curve in which the relative frequency of occurrence of various results are plotted (along the y-axis) as a function of the actual results (plotted along the x-axis). The curves are described by an equation having two parameters, the mean of the population, μ , and the standard deviation, σ , (**Eq 1-2**).

$$y = \frac{\left\{ \exp \left[\frac{-(x - \mu)^2}{2\sigma^2} \right] \right\}}{\sigma\sqrt{2\pi}} \quad (\text{Eq 1-2})$$

In **Figure 1-2** we show the results of analyzing a water sample known to be 40.0 ppm in calcium ion. The σ for one set of analyses (Sample A) is 0.10 and for Sample B the σ is twice as great. The σ determines the breadth of the curves shown in **Figure 1.2**. It is thus an indicator of the scatter of the data. The precision of the data leading to curve A of **Figure 1-2** is twice as good as the precision of the data leading to curve B.

If the number of results is infinite (in reality, more than 20-30), the population mean μ is equal to the true value for the measured quantity. When the number of results, N , is small, the replicate observations are called a sample, and the mean value \bar{X} is defined by **Eq 1-1**. In this instance \bar{X} differs from, μ and their difference decreases as N approaches 20-30. The σ for a population measures the precision of a population and is defined by

$$\sigma = \left[\frac{\sum (x_i - \mu)^2}{N} \right]^{\frac{1}{2}} \quad (\text{Eq 1-3})$$

If only a sample (small data set) is taken, **Eq 1-3** is no longer valid and if used, will give an estimated standard deviation that is too small. To obtain a better estimate of the standard deviation, **Eq 1-3** modified to:

$$s = \left[\frac{\sum (x_i - \bar{X})^2}{(N - 1)} \right]^{\frac{1}{2}} \quad (\text{Eq 1-4})$$

where μ from **Eq 1-3** has been replaced by \bar{X} and N by $(N - 1)$ (called the number of degrees of freedom).

Many scientific calculators have a function key for calculating the standard deviation. You should use your calculator instructions to learn how to calculate a standard deviation using your calculator. Generally, the experiments carried out in this manual call for determinations in triplicate. At least three results should be obtained to justify the use of **Eq 1-4** in estimating a standard deviation. Of more use as a measure of precision is the relative standard deviation, expressed in ppt:

$$\text{Relative Standard Deviation} = \left(\frac{s}{\bar{X}} \right) \times 1000 \text{ ppt} \quad (\text{Eq 1-5})$$

This property is the standard deviation, s , divided by the mean, \bar{X} . When expressed as a percentage it is called the coefficient of variation, CV, given by:

$$CV = \left(\frac{s}{\bar{X}} \right) \times 100 \% \quad (\text{Eq 1-7})$$

Both of these quantities allow a comparison of one set of data with another (a classmate, for example).

2. LEARNING OUTCOMES

At the end of this experiment, the student should be able to understand and apply the statistical concepts used in Analytical Chemistry.

3. CHEMICALS/REAGENTS

30 small objects of the same type and material.

4. METHODOLOGY

Obtain 30 small objects of the same type and material. Many possible objects will suffice, including weighing boats, coins and paper clips. Zero the balance each time you determine the mass of each object. Perform triplicate measurements for each object.

For the masses of objects weighed, prepare a table listing the masses in order of increasing mass. From the masses, calculate the following: (a) mean mass, (b) median mass, (c) the range of the masses, (d) the relative standard deviation in ppt, and (e) the coefficient of variation, CV.

The student is required to use graphical analysis on a computer to analyze the results.

According to the obtained data, plot a Gaussian curve to determine if they satisfy a Gaussian distribution.

5. QUESTION

Based on the obtained data, which types of error was involved during data collection? Explain your answer.

6. REFERENCES

- i. Skoog, D.A., West, D.M., Holler F.J., Crouch S.R., 2014. Fundamentals of analytical chemistry, 9th edition, Brooks/Cole, Belmont, CA.
- ii. Boehnke, D.N., Delumyea R.D., 2000. Laboratory experiments in environmental chemistry, Prentice Hall, New Jersey.

COMPLEXOMETRIC TITRATION OF METAL ION

1. INTRODUCTION

The titration of metals by chelating agents (complexometric titrations) developed rapidly after the initial work by Schwarzenbach about 30 years ago. The most important molecule in this field is the disodium salt of ethylenediaminetetraacetic acid (EDTA). EDTA forms stable complexes with almost all metals in a 1:1 molecular ratio. The reaction quickly proceeds near to completion for all practical purposes if a suitable pH is maintained.

Because of its wide applicability, EDTA lacks selectivity. Control of pH by buffer solutions may sometimes be used to enable two or more metal ions in a mixture to be titrated individually and successfully in the same solution. Masking agents are also frequently used. For example, potassium cyanide stabilizes silver, cadmium, mercury, iron(II), zinc, cobalt and nickel against EDTA complex formation permitting the titration of lead, manganese and alkaline earths in the presence of other metal ions. Potassium iodide likewise, is used in the masking of mercury in the determination of cadmium.

2. LEARNING OUTCOMES

At the end of this experiment, the student should be able to:

- i. understand and apply the concept of titration of metals by chelating agents such as EDTA.
- ii. determine the concentration of metal ions using complexometric titration technique.
- iii. determine the concentration of metal ions in mixture by pH adjustment and masking agent.

3. CHEMICALS/REAGENTS

Ethylenediaminetetraacetic Acid (approx. 0.01 mol/L)

Dissolve 3.72 g of ethylenediaminetetraacetic acid in a volumetric flask in distilled water and make up to a volume of 1 litre.

Xylenol orange Indicator (0.1% w/v)

Solochrome Black T/KCl Indicator mixture

Mix 1 part of solochrome black T with 99 part of potassium chloride (by weight) and stored in a bottle.

Hexamine solution (10% w/v)

Ammonia-ammonia chloride buffer solution (pH 10)

Dissolve 1.35 g ammonium chloride in about 5 mL distilled water. Add 10 mL concentrated ammonia solution dropwise into the beaker to adjust the pH of solution to pH 10, and transfer quantitatively the buffer solution into a 25 mL volumetric flask and make up to the mark with distilled water. Check the pH of the buffer solution.

4. METHODOLOGY

Standardization of EDTA

- i) Weight out approximately 0.15 g of zinc metal ("granulated zinc"), and dissolve fully in a few drops of 1:1 nitric acid.
- ii) Rinse the watch glass and the resulting solution quantitatively into a 250 mL volumetric flask, make up to the mark with distilled water and mix well.
- iii) Measure out 25 mL of zinc solution into a 250 cm³ conical flask, add 2 drops of xylenol orange indicator solution and dilute to about 100 mL with distilled water.
- iv) Add hexamine solution (10% w/v) until the solution becomes red-purple.
- v) Titrate the solution with EDTA. At the end point, the colour changes to yellow-orange.
- vi) Carry out the standardization in triplicate. **Calculate the molarity of the EDTA solution.**

Procedure for Determination of Bismuth and Lead (pH adjustment)

- i) Pipette 10 mL of first unknown solution into a 250 mL conical flask.
- ii) *Bismuth*: Add 2 drops of xylenol orange indicator solution and dilute to about 100 mL with distilled water. Titrate with standard EDTA solution until the colour changes from red-purple to clear orange-yellow.
- iii) *Lead*: Add hexamine solution (10% w/v) slowly until the colour becomes red-purple. Continue the titration with standard EDTA solution until a clear orange yellow colour is obtained again.
- iv) Carry out the determination in triplicate and calculate the concentrations of the metal ions in g dm⁻³.

Procedure for Determination of Cadmium and Mercury (back titration & masking agent)

- i) Pipette 10 mL of second unknown solution into 250 mL conical flask. Add 35 mL accurately measured excess of standard EDTA solution. After about 5 minutes, add a very small amount of solochrome black T/KCl indicator. Then add 10 -15 mL (same amount for triplicate) ammonia-ammonia chloride buffer (pH 10). Solution will turn dark blue.
- ii) Back titrate the excess EDTA solution with standard zinc solution (from the EDTA standardization) until the colour changes via blue to purple.
- iii) *Mercury*: Add about 1 g of potassium iodide to the titrated sample. Titrate the liberated EDTA with the standard zinc solution until a purple colour solution is obtained again. Carry out the determination in triplicate and calculate the concentrations of the metal ions in g dm⁻³.

REPORT

Explain the reactions involved using equations. Report the concentration of the metal ions in the mixtures in g dm^{-3} .

5. QUESTIONS

- i. Why should heating assist an EDTA reaction?
- ii. Would you expect positive or negative errors in the determination of Cd and Hg ions (or no error) ? If so, why?
- iii. What would happen in a titration of metal M with EDTA with indicator HxIn in the presence of a metal ion N that formed an indicator complex NIn that was more stable than the complex NY and the complex MIn.

6. REFERENCES

- i. J.S Fritz & G.H Schenk, Jr., "Quantitative Analytical Chemistry", 2nd ed., Allyn and bacon Inc., Boston 1973, p.211
- ii. Skoog, D.A., West, D.M., Holler F.J., Crouch S.R., 2014. Fundamentals of analytical chemistry, 9th edition, Brooks/Cole, Belmont, CA.
- iii. T.S West, "Complexometry with EDTA and related Reagents", 3rd Ed., BDH Chemicals Ltd, Poole, 1969

SPECTROPHOTOMETRIC DETERMINATION OF MANGANESE IN STEEL

1. INTRODUCTION

Plain carbon steel contains a certain amount of carbon, silicon, sulphur, phosphorus and manganese. For special purposes, varying amounts of other elements such as chromium, vanadium, molybdenum, tungsten, titanium, nickel, cobalt, zirconium and copper are added. The physical properties of steel depend highly on the content of these elements. Thus, the quantitative analysis of these elements is of great practical importance.

In this experiment, manganese is determined spectrophotometrically as the purple coloured permanganate ion, MnO_4^- . This is commonly used and an accurate method of determining the low concentrations of manganese in steel. The steel is dissolved in nitric acid to give a solution of manganese (II) ions. The periodate ion, added as the potassium salt, KIO_4 , readily oxidizes manganese (II) to permanganate according to (Eq 3-1):

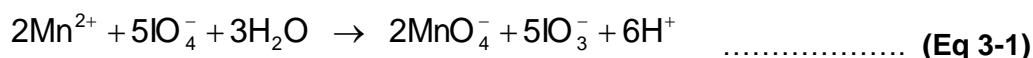

The calibration curve is determined by measuring the absorbance of a series of standardised permanganate solution prepared. The permanganate can be accurately standardised using a primary standard, sodium oxalate. The oxalate anion, $\text{C}_2\text{O}_4^{2-}$ reduce permanganate to manganese (II) in acid solution at 60-70°C according to (Eq 3-2):

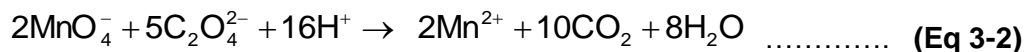

Note:
Manganese in steel can be quantified by oxidizing Mn to MnO_4^- , which has an intense purple colour. The concentration of manganese can then be determined by measuring the intensity of the purple colour, and comparing it with the colour of known permanganate solutions.

2. LEARNING OUTCOMES

At the end of this experiment, the student should be able to:

- i. understand and apply Beer's Law in spectrochemical analysis.
- ii. determine spectrophotometrically manganese as permanganate ion, MnO_4^- in steel.

3. CHEMICALS/REAGENTS

Potassium Permanganate Solution (1.00 g Mn dm³)

Dissolve 2.877 g potassium permanganate in 1 liter of distilled water.

Sulphuric Acid (5 mol dm⁻³)

4. METHODOLOGY

Standardization of Permanganate with Oxalate (conduct in fume hood)

An approximately 1.000 g Mn dm⁻³ solution will be supplied. Standardise this solution with oxalate solution as follows:

- i) Weigh out accurately about 1.6 g of sodium oxalate and make up to 250 cm³ in a standard flask.
- ii) In a fume hood, acidify a 25 cm³ aliquot with 5 cm³ of 5 mol dm⁻³ sulphuric acid, warm the mixture to 60-70°C and titrate with potassium permanganate until a faint pink coloration persists for at least 30 seconds.

From the mean of three concordant titrations, calculate the concentration of the potassium permanganate solution.

Determination of the Calibration Curve

Accurately dilute the standard potassium permanganate solution and prepare a series of five standards in the concentration range between 2 to 10 mg/L. Measure the absorbance of these five solutions using a spectrophotometer set at 525 nm. Use water as the reference solution.

Determination of manganese in steel

Safety note: This part of the experiment should be carried out in the fume hood

- i) Accurately weigh out duplicate (i.e. x 2) sample (approx. 0.2 g) of the steel sample into 150 cm³ beakers.
- ii) Cover the beaker with watch glass; add 30 cm³ of 1:1 nitric acid.
- iii) Warm to dissolve the alloy and then heat to gentle boiling for a few minutes to expel oxides of nitrogen.
- iv) Cautiously add about 1 g ammonium peroxydisulphate and boil for 10-15 minutes. If the solution is pink or contains brown oxide of manganese (as a deposit of MnO₂) add about 0.1 g sodium bisulphate and heat for 5 minutes.
- v) Cool, rinse down the watch glass and transfer the solution quantitatively to a 100 cm³ volumetric flask and dilute to the mark with distilled water.
- vi) Pipette two 25 cm³ aliquots of the sample solution into small beakers and add 5 cm³ of phosphoric acid.
- vii) To one of the two aliquots add 0.5 g KIO₄ and boil the solution for 5 minutes.
- viii) The second aliquot is not treated with periodate and will serve as the blank.
- ix) Cool to room temperature, transfer each aliquot quantitatively to a 50 cm³ volumetric flask and dilute to the mark with distilled water.
- x) Measure the absorbance of the solution and the blank.

REPORTS

Prepare a calibration curve from the data obtained by plotting absorbance versus concentration.

From the measured absorbance values of the unknown sample duplicates, determine the concentration of MnO_4^- from the calibration curve after making corrections due to sample blank.

Express the final result as the percentage of manganese in steel turnings.

5. QUESTIONS

- i. What is the purpose of using the following chemicals in this experiment? Briefly discuss their purpose and the chemical reactions involved.
 - a) Nitric acid
 - b) Bisulphite
 - c) Phosphoric acid
 - d) Peroxydisulphate
- ii. Can water be used as a blank in the measurement of the absorbance of the standard solutions?
- iii. "The measurement of the absorbance due to the sample blank is essential" Comment on the above statement.

6. REFERENCE

Skoog, D.A., West, D.M., Holler F.J., Crouch S.R., 2014. Fundamentals of analytical chemistry, 9th edition, Brooks/Cole, Belmont, CA.

ELEMENTAL ANALYSIS BY FLAME ATOMIC SPECTROSCOPY

1. INTRODUCTION

Atomic spectroscopy is one of the most widely used techniques in analytical chemistry for quantitative elemental analysis. There are certain conditions when the analysis needs to be carried out to determine the elemental composition. These conditions are such as

- How much iron is in an ore sample?
- How much lead is in your drinking?
- What is the content of mineral water?
- Are the water samples containing toxic elements?

In the laboratory, elemental analysis can be performed using an atomic spectroscopy instrument. This experiment is designed to give you a little experience with AAS (Atomic Absorption Spectroscopy) and AES (Atomic Emission Spectroscopy) for the quantitative determination of a few elements. In this experiment, you will use flame atomic absorption spectroscopy (AAS) to determine the concentrations of Ca^{2+} , Mg^{2+} and iron (Fe) in mineral water. Atomic emission spectroscopy (AES) is a method for the determination of alkali metals in water samples. These metals are excited in flames and can be determined by flame emission. In this experiment, you will use AES to determine concentrations of sodium (Na^+) in mineral water.

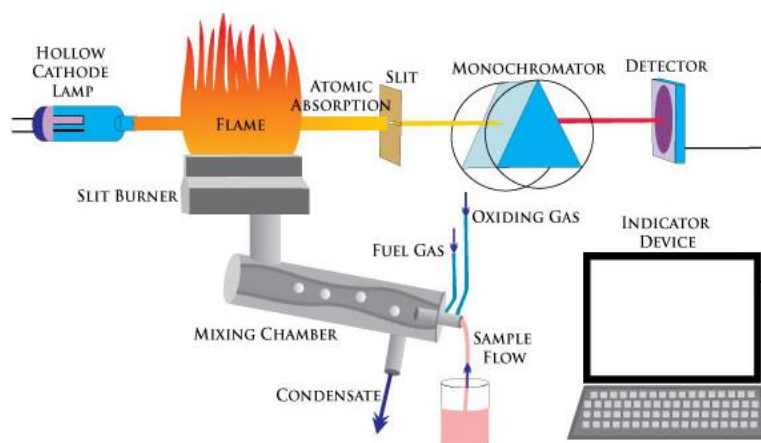

Figure 1: Schematic diagram of AAS.

2. LEARNING OUTCOMES

At the end of this experiment, the student should be able to:

- apply atomic emission and absorption spectroscopy for the analysis of metals,
- perform quantitative determination of a few elements in water samples

Experiment 4 Lab Manual Analytical Chemistry I: SIC2004/SIC2022/SID2003

3. CHEMICALS/REAGENTS

Standard stock solution of calcium, magnesium, sodium & iron

4. METHODOLOGY

Determination of calcium, magnesium and iron using AAS

1. Request for the standard solution of calcium, magnesium and iron from the lab assistants. Record the concentration of these standard solutions.
2. Prepare 5 standard solutions for each element using a 50 mL volumetric flask. The concentrations of the standard solutions should be within the range as presented in the table below.

Element	Concentration range (mg/L)
Ca	0.10 – 0.50
Mg	0.02 – 0.15
Fe	0.25 – 3.0

3. Mineral water is used as an unknown sample. You may need to dilute the unknown samples (3 in 50 and 1 in 100) before measurement if it is too concentrated. Record the dilution factor.
4. Set up the flame atomic spectrophotometer (please consult the Lab Assistant). Measure the complete set of standards and unknown samples before switching to another element. Use AAS mode for the measurement of calcium, magnesium and iron.

Determination of sodium using AES

1. Using the stock solution, prepare 5 standard calibration solutions with the concentration ranging from 0.05 – 4 mg/L.
2. Mineral water is used as an unknown sample. Dilute the sample (3 in 50 and 1 in 100) if the measured absorbance is too large – i.e., outside of the range of the standards. Record the dilution factor.
3. Measure the standards and unknown in AES mode for the measurement of sodium.

REPORT

- i. Tabulate and plot the **absorbance** vs concentration for calcium, magnesium, and iron. Derive the calibration equations and calculate the concentration of the selected elements in the unknown sample.
- ii. Tabulate and plot the **emission** intensity vs concentration for the sodium standards and derive the calibration equation. Calculate the concentration of sodium in the unknown sample.
- iii. Use Microsoft Excel to tabulate and prepare the absorbance vs concentration calibration plot for sodium, calcium, magnesium, and iron. Define the **Limit of Detection (LOD) and Limit of Quantitation (LOQ)**. Calculate the LOD and LOQ based on the calibration plots by using the following equations:

a. $LOD = 3.3 \left(\frac{S_y}{S} \right)$

b. $LOQ = 10 \left(\frac{S_y}{S} \right)$

Where S_y and S is the standard deviation of the response and slope of the calibration plot, respectively, you can use the LINEST function in Excel to calculate the S_y and S (<https://www.youtube.com/watch?v=6wbcPbYbq6M>) or Data Analysis function in Excel (<https://www.youtube.com/watch?v=CnDdEYgxLjQ&t=309s>).

- iv. Discuss the obtained results by referring to the Malaysia Drinking Water standard.
- v. Explain why LOD and LOQ are important and whether your results are within the limit.

5. QUESTIONS

- i. Why is flame emission a more sensitive technique for some cations, mainly the alkaline and earth alkali cations, while atomic absorption has greater sensitivity for other cations, such as the transition metal ions?
- ii. Explain why AAS is so selective, i.e. why do other elements not usually interfere in the analysis?

6. REFERENCE:

Skoog, D.A., West, D.M., Holler F.J., Crouch S.R., 2014. Fundamentals of analytical chemistry, 9th edition, Brooks/Cole, Belmont, CA.

SEPARATION OF ANIONS BY ION EXCHANGE CHROMATOGRAPHY

1. INTRODUCTION

The anion exchange resin used in this experiment (Deacidite FF' or Amberlite) is a cross linked polymer containing quaternary ammonium groups as integral parts of the polymer lattice and an equivalent amount of chloride anions. The anion exchange resin, originally in the chloride form, is converted into the nitrate form by washing with sodium nitrate solution.

The function of the ion exchange resin depends on the following chemical equilibrium:

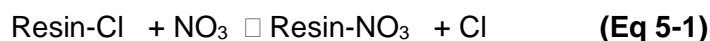

The above equation shows that concentrated nitrate ions will shift the equilibrium to the right and chloride ions will be eluted from the column slowly. During the process, there is a difference in concentration of nitrate and chloride ions, hence equilibrium exists along the length of the column. The process of elution should be allowed to run slowly to attain equilibrium stability. Ion exchange procedure is used widely in synthesis and analysis. One important usage is in the separation of the actinide and lanthanide elements.

In this experiment, a mixture of chloride and bromide ions will be separated quantitatively. These two anions exchange readily with the resin-nitrate, i.e. equilibrium shifts to the left in **(Eq 5-1)** when the solution mixture is poured into the column. The anions are eluted from the column when a solution of sodium nitrate is passed through the column. Separation is possible as bromide ion is adsorbed stronger than the chloride ion (K_{eq} for Br < K_{eq} for Cl). The progress of separation is followed by titrating 10 cm³ fraction of the eluate with standard silver nitrate solution. This titration uses chromate ion (CrO₄²⁻) as an indicator. Low concentration of the indicator is needed to achieve its end point when excess Ag⁺ is added. Blank titration is done to determine the actual volume of silver nitrate needed to form Ag₂CrO₄ and to determine the end point.

2. LEARNING OUTCOMES

At the end of this experiment, the student should be able to:

- i. demonstrate the chromatographic separation of inorganic anions.
- ii. quantitatively determine the percentage of anions recovered from the column.

3. CHEMICALS/REAGENTS

Deacidite FF' or Amberlite Ion exchange resin

Dilute nitric acid

0.30 mol dm⁻³ sodium nitrate

0.20 mol dm⁻³ Potassium chromate

A.R Sodium chloride

A.R Potassium bromide

0.05 mol dm⁻³ Silver nitrate

4. METHODOLOGY

Preparation of Column

- i) Wash about 25 g of resin with distilled water in a beaker for several minutes. Any fine particles are removed by decantation, and **the washing procedure is repeated several times until the color of the decanted washing is clear.**
- ii) Wash the resin with dilute HNO_3 then perform the silver nitrate test on the washings to check that it is free from chloride ion.
- iii) Transfer the resin slurry portion wise into a column that has a glass-wool plug at the lower end and is filled with water. (The tube may be tapped gently to prevent the formation of air bubbles).
- iv) Fill a separating funnel with $0.30 \text{ mol dm}^{-3} \text{ NaNO}_3$ and elute HNO_3 from the column for 15 minutes.

(To obtain a satisfactory separation, it is essential that the solutions should pass through the column in a uniform manner. The resin particles should be packed uniformly in the column: the resin bed should be free from air bubbles so that there is no channeling)

Blank

Before commencing the elution, titrate 10.0 cm^3 of the 0.30 mol dm^{-3} sodium nitrate (with 2 drops of potassium chromate as an indicator) with the standard silver nitrate solution that has been **diluted ten times**. Color changes from yellow to red-brown. (***Do not forget to change the volume to original concentration for determination of chloride and bromide.***)

Determination of chloride and bromide

- i) Weigh out accurately 0.10 g of sodium chloride, and 0.20 g of potassium bromide. Dissolve in about 2.0 cm^3 of water and transfer quantitatively to the top of the column with the aid of 0.30 mol dm^{-3} sodium nitrate.
- ii) Pass 0.30 mol dm^{-3} sodium nitrate through the column **at a flow rate of about 1 cm^3 per minute** and collect the effluent in 10 cm^3 fractions using a 10-cm^3 measuring cylinder.
- iii) Transfer each fraction in turn to a conical flask and add 2 drops of potassium chromate solution as an indicator and titrate with standard 0.05 mol dm^{-3} silver nitrate.
- iv) Plot a graph of the concentration of halide in each fraction (millimoles per liter) against the volume of effluent collected. From the graph, calculate the percentage of chloride ion and bromide ion recovered.

The titer falls to zero after all the chloride ions have been eluted and increases as the bromide ion is eluted from the column. Do not forget to deduct the blank volume for each titration.

At the end of this experiment, discard the resin in the "waste resin" bottle and **NOT** down the sink.

5. QUESTIONS

- i. Why does the bromide ion adsorb stronger to the column compared to the chloride ion?
- ii. How is pipe water deionised?

6. REFERENCE

A Textbook of Quantitative Inorganic Analysis by A.I. Vogel.

INTRODUCTION TO GAS CHROMATOGRAPHY

1. INTRODUCTION

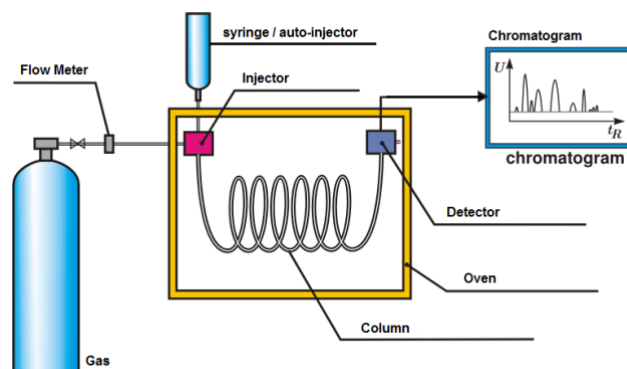

Chromatography involves separating a mixture of analytes according to their partitioning between a stationary phase and a mobile phase. Gas chromatography (GC) is a very powerful and one of the most common instrumental analysis techniques in use. When properly utilised, it provides both qualitative (i.e., what is it?) and quantitative (i.e., how much?) information about individual components in a sample. The mobile phase of GC is an inert carrier gas (e.g. nitrogen, helium, hydrogen, etc) and the stationary phase is found in the column. The gas chromatograph used in this experiment is equipped with a capillary column..



The sample (dissolved in organic solvent) is injected onto the GC through a septum into a heated injection port. The temperature of the injector is selected so as to vapourise the sample upon injection. The sample vapour is then carried through the column by the carrier gas. As they interact with the stationary phase to varying degrees, they are separated. With nonpolar stationary phases, the principal determining factor as to relative retention times on the column is the volatility of the analytes. Therefore, the elution order is often estimated using the boiling points of the analytes. The detector temperature is chosen to be at least 20°C higher than the highest boiling point, in order to ensure all analytes are detected as gases.

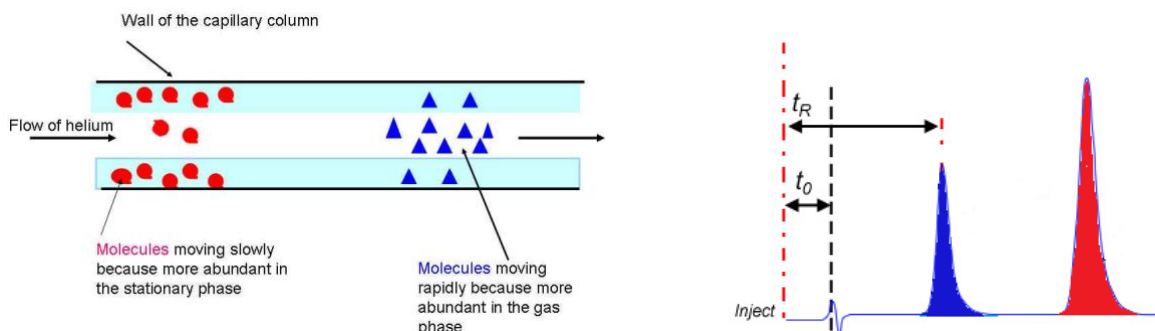

To get a better and more efficient separation of analytes, *temperature programming* is often employed. The temperature of the column is raised during the course of the analysis as shown in Figure 1.

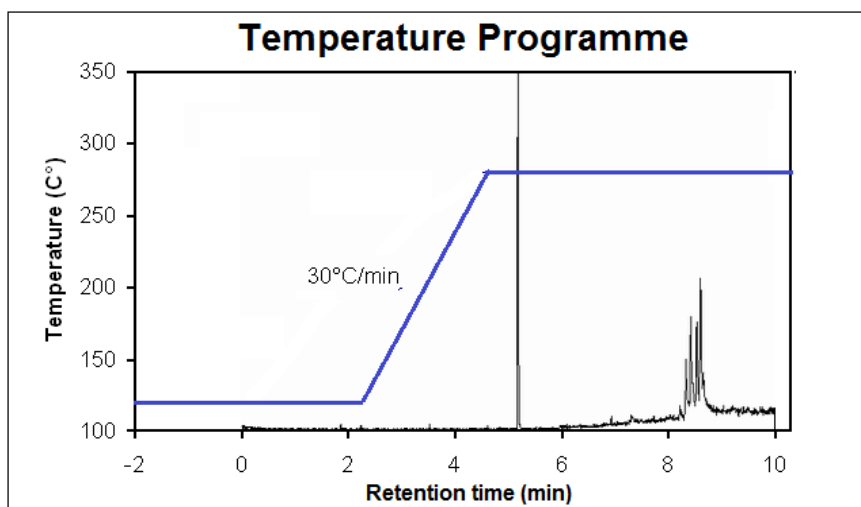

Figure 1

1.2 BTEX

BTEX refers to benzene, toluene, ethylbenzene and xylenes. BTEX are an important class of volatile environmental contaminants, and are frequently analyzed in environmental and drinking waters. Regulations often require that all waste entering the municipal sewer system contain no more than 1 mg/L. In this experiment, BTEX will be quantified using the external standardization technique.

2. LEARNING OUTCOMES

At the end of this experiment, the student should be able to:

- i. get familiar with gas chromatography and its basic components
- ii. gain experience in temperature programming and method development
- iii. correctly use an external standard

3. CHEMICALS/REAGENTS

Hexane, toluene, ethylbenzene, o-xylene and p-xylene.

4. METHODOLOGY

- a) Prepare 5 BTEX calibration standards between 10 – 50 mg/L. The solvent for the preparation is hexane and the solutions should be prepared in the fume hood.
- b) Obtain an unknown sample from the laboratory assistant. Please write the assigned unknown samples.
- c) Place approximately 1 mL of all standards and unknown into a standard 1.5 mL vial with silicon septum.
- d) Analyse the standards and sample using manual injection.

Instrumental parameters:

Initial temperature	50°C, hold for 5 min
Ramp rate	10°C/min
Final temperature	150°C, hold for 1 min
Carrier gas	Nitrogen
Oxidant	Compressed air
Fuel	Hydrogen gas

5. REPORT

- a) Plot analytical calibration curves for all 4 BTEX components. From these curves, determine and report the concentration of each component of BTEX in the unknown sample in ppm.
- b) Discuss the external standardization method which was used in this experiment and comment on the calibration plot achieved.

5. QUESTION

Discuss the advantage of temperature program (ramping) over isothermal separation.

6. REFERENCES

- i. Skoog, D.A., West, D.M., Holler F.J., Crouch S.R., 2014. Fundamentals of analytical chemistry, 9th edition, Brooks/Cole, Belmont, CA.
- ii. Harvey, D., 2000. Modern analytical chemistry, McGraw Hill, Boston.

DIRECT POTENTIOMETRY USING ION SELECTIVE ELECTRODE

1. INTRODUCTION

An ion selective electrode is designed to develop a potential in response to the activity of the ion for which it is selective. In dilute solution the activity of an ion approaches concentration and thus such electrodes are useful for determining the concentration of ion under these conditions. This is particularly so when electrode response is compared with a calibration graph using a solution of known concentration. The specific ion electrode may also be used as an indicator electrode to detect the end point of a titration. A wide range of ion selective electrodes are available such as bromide, cadmium, chloride, cupric, cyanide, fluoride, iodide, lead, nitrate and sodium ions.

The sensing element in the fluoride ion selective electrode is a specially treated crystal of lanthanum fluoride, but the electrode must be used in conjunction with a reference electrode. The reference electrode may be separate but the fluoride electrode is available as a combination electrode with the reference built into the electrode. The relationship between ion activity and electrode potential is logarithmic.

$$E = E_a - 2.3 \frac{RT}{F} \log a_{F^-} \quad E_a \text{ is constant}$$

where a_{F^-} is the activity of the fluoride ion in the sample solution. When sensing an anion the electrode potential becomes more negative with increasing ionic activity. At 25°C the electrode potential changes by 59.1 mv for a tenfold change in ionic activity if the ion being measured is monovalent. The lower limit of detection is determined by the solubility of the electrode sensing element. Most interferences are eliminated by the addition of a buffer solution containing citrate. Note the composition of the TISAB (Total Ionic Strength Adjustment Buffer) solution used in the experimental section.

2. LEARNING OUTCOMES

At the end of this experiment, the student should be able to:

1. Understand the fundamental of electrochemical or potentiometric technique in chemical analysis, and
2. Apply a potentiometric method for the determination of ions.

3. CHEMICALS/REAGENTS

Total Ionic Strength Adjustment Buffer (TISAB)

Dissolve 58 g AR sodium chloride and 0.30 g sodium citrate in a mixture of 500 g cm⁻³ distilled water and 57 cm³ glacial acetic acid (pure). Cool in a water bath while adding 5 mol dm⁻³ sodium hydroxide until the pH is between 5.0 and 5.5 (use a pH meter). Cool and dilute to 1 liter with distilled water.

Electrode Filling Solution

Dissolve 250 g AR potassium nitrate and 4 g AR sodium chloride in 1 liter distilled water. Add 100 mg methylamine and a small amount of solid silver chloride and shake overnight in a plastic bottle. Store in the dark with a small amount of silver chloride in the solution.

Standard Fluoride Solution (10 mg dm⁻³ fluoride)

Dissolve 0.221 g anhydrous sodium fluoride in and make up to 1 liter with distilled water to prepare 100 mg dm⁻³ fluoride stock solution. Dilute 100 cm³ of stock solution to 1 liter with distilled water. Store in a polyethylene bottle.

4. METHODOLOGY

Preparation of Standard Solutions

By serial dilution of the 10.0 mg dm⁻³ fluoride standard solution, prepare 3 sets of 0.2, 0.4, 0.8, 1.2, 1.6, 2.0 mg dm⁻³ fluoride standards in 50 mL volumetric flasks. Dilute each to the mark with distilled water and mix well.

Take 10 cm³ of each of the above solutions and add 10 cm³ Total Ionic Strength Adjustment Buffer in 25 cm³ beakers. Prepare also a blank solution containing no fluoride by adding 10 cm³ TISAB to 10 cm³ distilled water. Place the beaker on a stirring plate, add a magnetic stirring bar and stir at a constant rate for 3 minutes. Measure the potential developed by the electrode one set at a time. Rinse the electrode with distilled water before each measurement and dry with a soft tissue. Insert the electrode into the stirred solution and record the reading after the reading is stable.

Analysis of Unknown Samples (Tap water and provided unknown solution)

Treat the unknown sample and tap water sample similarly. Prepare 3 sets of 10 cm³ unknown and 10 cm³ tap water. Add 10 cm³ TISAB solution to all solutions. Measure the electrode potential under conditions identical to those used for the standard solutions and obtain the fluoride concentrations from the calibration graph. Find the average values based on the three measurements.

5. REPORT

- a) Plot the potential readings versus the log concentration of the standard solutions. Report the concentration of the unknown fluoride in mg dm^{-3} .
- b) Discuss whether the obtained calibration plot obeys the Nernst equation.

6. QUESTIONS

- a) Why does the Nernstian response curve (mV versus concentration) begin to level off at low fluoride concentration?
- b) Why are stock sodium fluoride solutions stored in polyethylene rather than glass bottles?

7. REFERENCE

Joseph Wang, "Analytical Electrochemistry", 3rd edition, Wiley VCH. 2006, ISBN 978-0-471-67879-3